



42/52000

VariFlow 10000 / 20000 / 30000/ 42000/ 52000

OWNER'S MANUAL

Introduction

Congratulations on your purchase of one of the most advanced technological pumps on the market. With PondXpert VariFlow you have full control over the water flow from your pump.

The pumps are carefully inspected and tested to ensure both safety and operating performance. However, failure to follow the instructions and warnings in this manual may result in pump's damage and/or serious injury. Be sure to read and save this manual for future reference.

Performance Parameters Table

Model No:	Control Box (W)	Max Power Watts	Max Flow (L/H)	Max Head (Mtr)	Min Flow (L/H)	Min Power Watts	Hose Tail Fittings
PXVF10000	100W	85W	9200	5.0m	4400	15W	20/25/32/38
PXVF20000	200W	187W	19800	7.0m	9300	34W	25/32/38/50
PXVF30000	400W	385W	30000	10.0m	12000	45W	25/32/38/50
PXVF42000	450W	450W	42000	6.5m	32060	105W	3" Outlet
PXVF52000	600W	600W	52050	8.5m	30658	180W	3" Outlet



All pumps voltage: AC220-240V 50/60Hz.

2m power cord to LCD controller unit then 8m power cord to pump.

Control and Panel Function

LED figures on LCD screen indicates the wattage output going to the pump.

There are three buttons located on the control panel with the following functions:

-  Pump 'On' or 'Stop'
-  Slow water flow (reduce power)
-  Increase Flow (increase power)

Operating instructions

After first attaching power to the unit a Power setting is revealed on LED display ('PXXX' in red digitals).

"P" is short for "power" and this is how much power is going through to the pump in watts. When slow/fast button is pressed the "Flow" or 'F' setting is revealed – there are 70 flow settings from 030 to 100. Press Slow or Increase to reveal setting, press again in quick succession to change setting by one level, leave finger on button for rapid increase/decrease.

Led Protection Mode

To protect the LED Screen after 30 seconds without touch the LED changes from micro bright to the screen saver mode; Press any button to return to normal.

Memory Function

Control Panel stores the last setting used. It will retune to this setting when re-connected.

Fault Code Description

Using intelligent circuitry, the control panel will sense any pump malfunction and will return an error code to the LCD display for viewing. We include suggested remedies.

Er01: Abnormal working current; **Check if pump short of voltage or controller broken**

Er02: Controller over-heating; **Check if Controller positioned in sun or high temperature**

Er03: Pump idling; **Check the Pump works dry.**

Er04: The impeller stopped turning; **Clean Pump & Impellor until impellor turns freely.**

Er05: Abnormal running voltage; **Check input supply voltage.**

Auto-Off Function

Should your pond or water reservoir become too shallow for the pump to operate correctly sensors built into the pump will detect this. After a period of two minutes unless this situation is rectified, the pump will switch off automatically to prevent motor damage.

Methods of Use

Your pump must always be immersed in water before it is switched on. The pump can be submersed or run externally. In "dry" use water flow should be connected to the water intake hose. As the name implies an external pump sits outside of the pond in a dry location.



Fig. A) VariFlow Submerged

Fig. B) VariFlow Dry Mounted

Pump can be positioned underwater (fig. A) or dry-mounted (Fig. B)

General safety Instructions

Read and observe all of the instructions clearly before installing, connecting and operating the pump. Make sure the pump is securely and correctly installed before switching on.

Always disconnect the pump when not in use and when carrying out maintenance.

Always disconnect all equipment in the pond before starting to handle, maintain, repair or install any pond equipment.

The appliance is not intended for use by persons (including children) with reduced physical, sensory or mental capabilities, or lack of experience and knowledge, unless they have been given supervision or instruction concerning use of the appliance by a person responsible for their safety.

Children should be supervised to ensure that they do not play with the appliance.

For safety reasons, servicing or repair of this item should only be carried out by PondXpert.

Never hang or carry the pump by the power cord.

Do not operate the pump with a damaged cord or plug. The supply cord of the appliance cannot be replaced.

If the electrical cord is damaged the product should be scrapped.

Safety and Electrical Connections

This unit is designed for outdoor use only. Take care to ensure that you can easily lift your pump out of the water for routine maintenance. If this is necessary do not pick your pump up by the electrical cable but by the main body/ cage of the pump.

Always disconnect all equipment in the pond before starting to handle, maintain, repair or install any pond equipment.

The pump is electrically operated so great care must be taken during installation and operation. The following electrical and safety guidelines must be carefully followed.

Each pump is supplied with an 8 metre length of 3 core electrical cable which is permanently connected to the pump.

Safe Operation Conditions

The pump maximum operating depth is 1.5 meters. (2m for 42/52000).

Pump can handle solid particles up to 6mm.

Pump can be used in salt or freshwater conditions.

The LCD Control Unit is weatherproof and there are four slots on the unit to provide the opportunity for wall fastening. For longer life it is advised that the unit is sheltered and protected as much as possible from the weather to prevent UV damage or water ingress.

Pump – Electrical Safety

Each pump is supplied with a 8metre length of 3 core electrical cable which is attached to the Control Unit via a plug-in connector. A 2m length of permanently attached power cable runs from the connector to the mains supply.



The wires in the mains electrical lead are coloured in accordance with the following code:

BLUE – Neutral (marked with an “N” in most terminal connections)

BROWN – LIVE (marked with an “L” in most terminal connections)

GREEN/YELLOW – EARTH (marked “E” or  in most terminal connections)

1st January 2005 revised Building Regulations for England and Wales
Installing this product in the garden is classified as ‘notifiable’. The Regulations now require you to tell your local authority building control department that you intend to install this product before installation. Your local authority will let you know how you can get your installation approved

The termination to the mains supply should be permanent, inside a dry weatherproof enclosure, through a double pole switched fused spur with a minimum contact gap of 3mm – (disconnected) to BS 3676 – and fitted with a 3 or 5 amp fuse.

Exposed cable runs should be sensibly positioned, and protected if necessary, by armoured conduit.

A 10mA or 30mA Residual Current Circuit Breaker (RCD) MUST be fitted to the mains supply.

Permanent installations to the mains supply (hard wiring) must comply with the regulations of the local electricity authority which may stipulate the use of metal or plastic conduit to protect the cable.

If in any doubt about wiring to the mains supply contact a qualified electrician or your local electricity authority.

Protect from frost. In cold winter weather (when fish are inactive and algae growth ceases) the pump may be switched off. It should then be drained of water, removed (if possible) from its installation and stored in a dry, frost-protected area.

Directions for use

Installation

Once installed the pond water will flow through the pump as the pump’s impellor draws in water. It is always best to position your pump at the opposite end to where the water returns to the pond to provide maximum circulation.

10000, 20000, 30000

Your pond is supplied with a hoesetail. This should be screwed into the threaded pump inlet. Pond hose size 20-50mm (3/4” to 2”) can be attached to the inlet hoesetail

(depending on model). Cut the inlet hose to the size appropriate to the size of hose you are using. Then connect the hose from your pump to your filter system or position it where you want the water to return. Ensure a watertight seal by the use of hose clips.

42000, 52000

Pump is supplied without a hoesetail or filter cage. Retailer to supply separately.

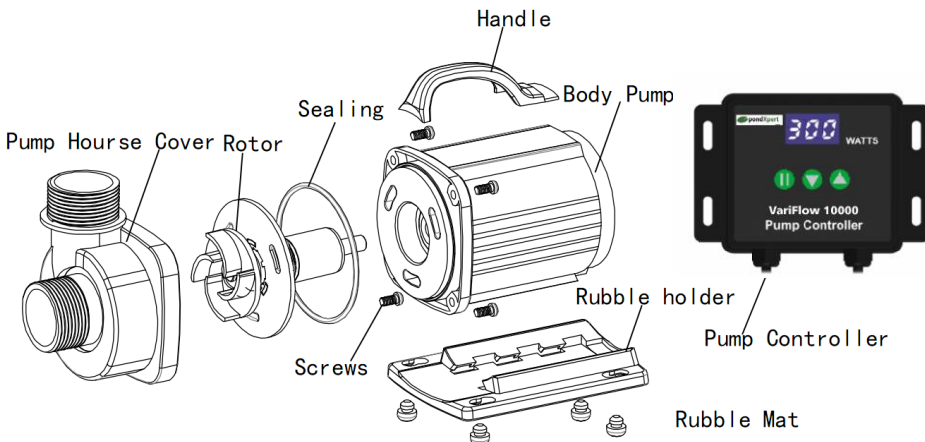

MAINTENANCE

To clean the pump, remove the back cover, sealing cover and the rotor/impeller. Use a small brush or stream of water to remove any debris. Note: pump shaft can not be removed. If the pump does not work, check the following:

- Check the circuit. Please try unit on another power socket.
- Check the pump outlet and tube. Algae and dirt may block them up
- Check the inlet to ensure not clogged by debris.
- Remove the pump inlet to access the impeller. Turn the rotor to check if broken or jammed.

- Monthly maintenance prolongs your pump's life. Clean rotor, remove the dirt. etc

NOTE: Ensure the electrical cord loops below the power socket like a "Drip Loop". It will prevent the water from running around the cable into the power socket

Limited Warranty

This product is guaranteed for a period of 36 months (excluding rotor assembly) from the date of purchase for material or manufacturing defects. The guarantee covers the substitution of defective parts. However, the guarantee is considered null and void in the case of improper use, improper handling or negligence on the part of the buyer. If your pondXpert pump fails please take it back to the retail outlet from where it was purchased. You will be required to take your receipt/proof of purchase with you. This does not affect your statutory rights.

PondXpert
A3 Bentley Avenue
Billingham
TS23 4BU
UK

01642 370898
www.pondxpert.co.uk



Your appliance contains valuable materials which can be recovered or recycled. Leave it at a local civic waste collection point.